

# Metabolic Engineering for Robust Natural Product Biosynthesis in *C. glutamicum*

Jason Ronstadt, Chemical Engineering  
Mentor: Arul M. Varman, Assistant Professor  
School for Engineering of Matter, Transport & Energy

## Objective

- To engineer a pathway within *C. glutamicum* that would allow the cell to produce naringenin.
- Significance: Naringenin is a natural product that has pharmaceutical and agricultural applications. This method will allow naringenin to be produced more sustainably.

## Methodology

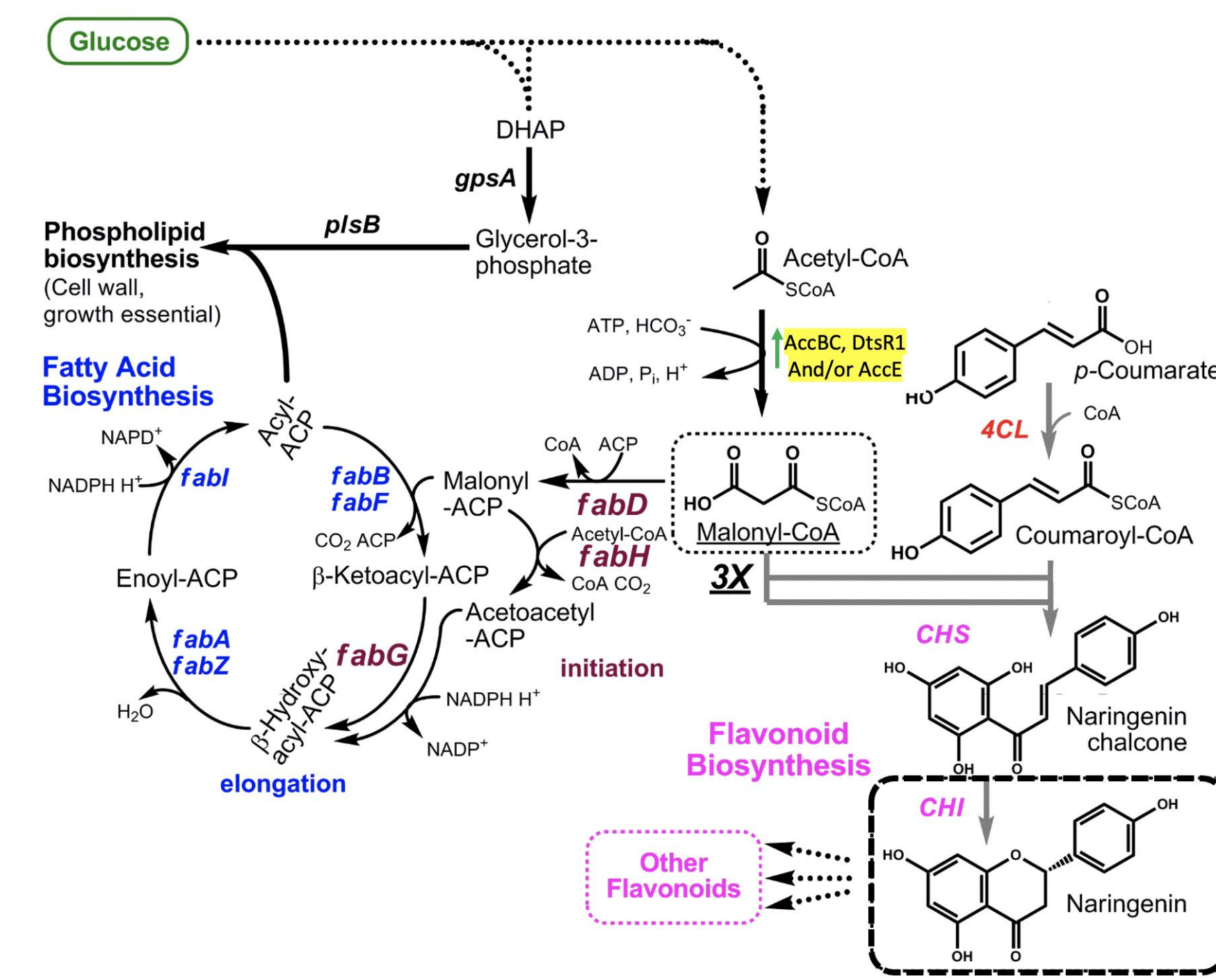
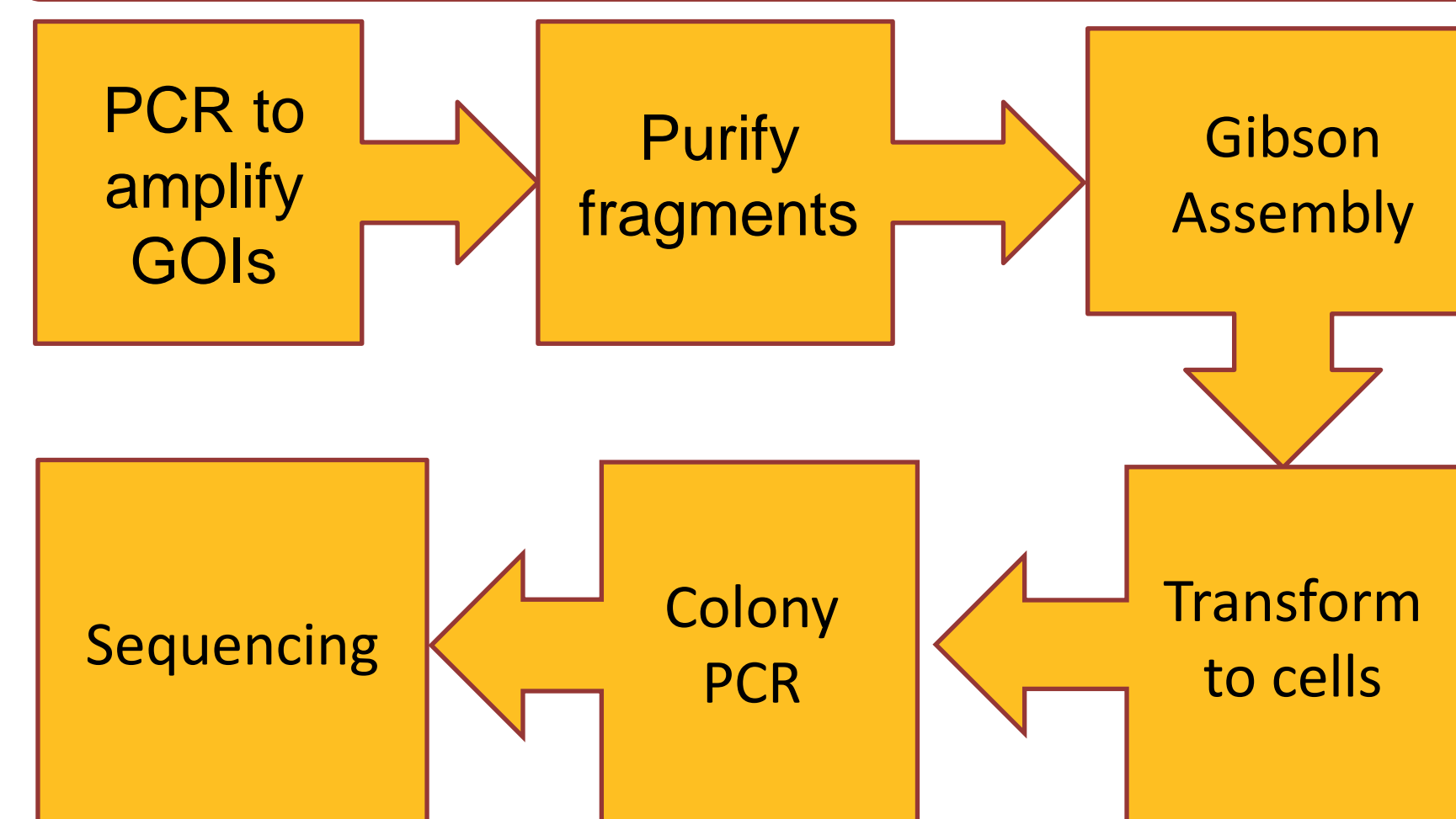

## Experimental Design

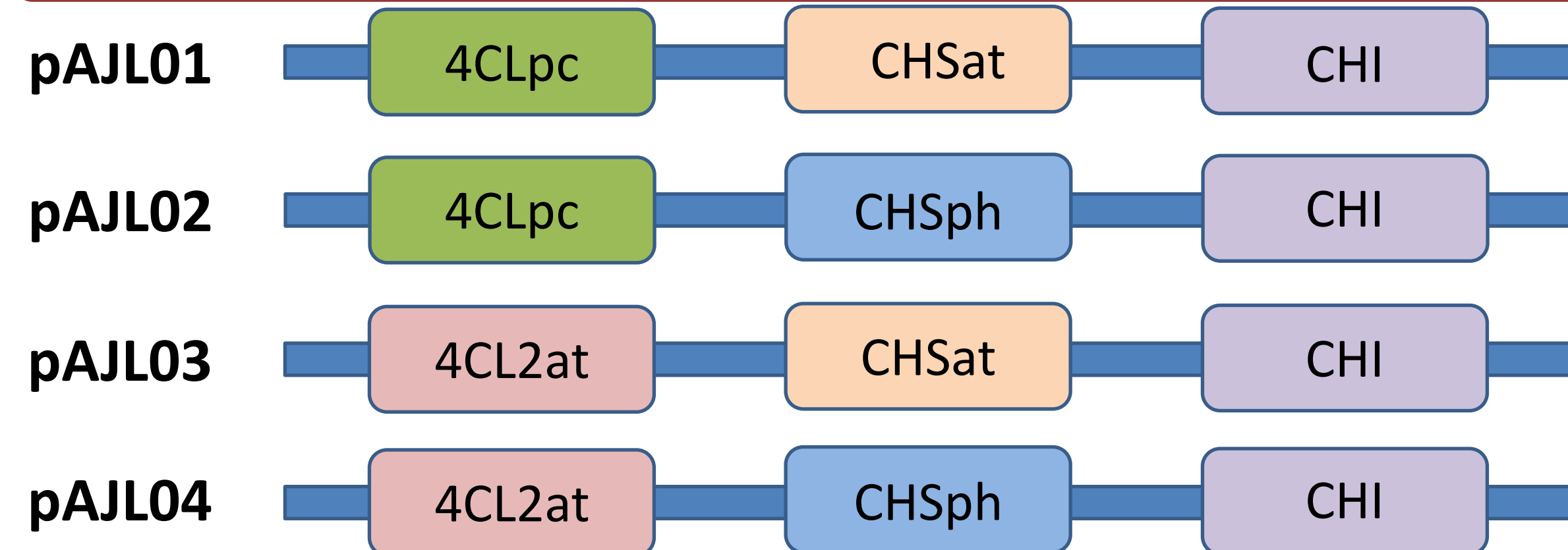

## Current Results

### pAJL01

- Resulted in many background colonies
- Will assemble again once pAJL04 is successfully transformed

### pAJL02

- Successfully assembled and transformed
- Currently being sequenced

### pAJL03

- Had trouble cloning with 4CL2at
- Will assemble once pAJL04 is confirmed

### pAJL04

- In progress; successfully assembled
- Currently running colony PCRs to confirm transformation

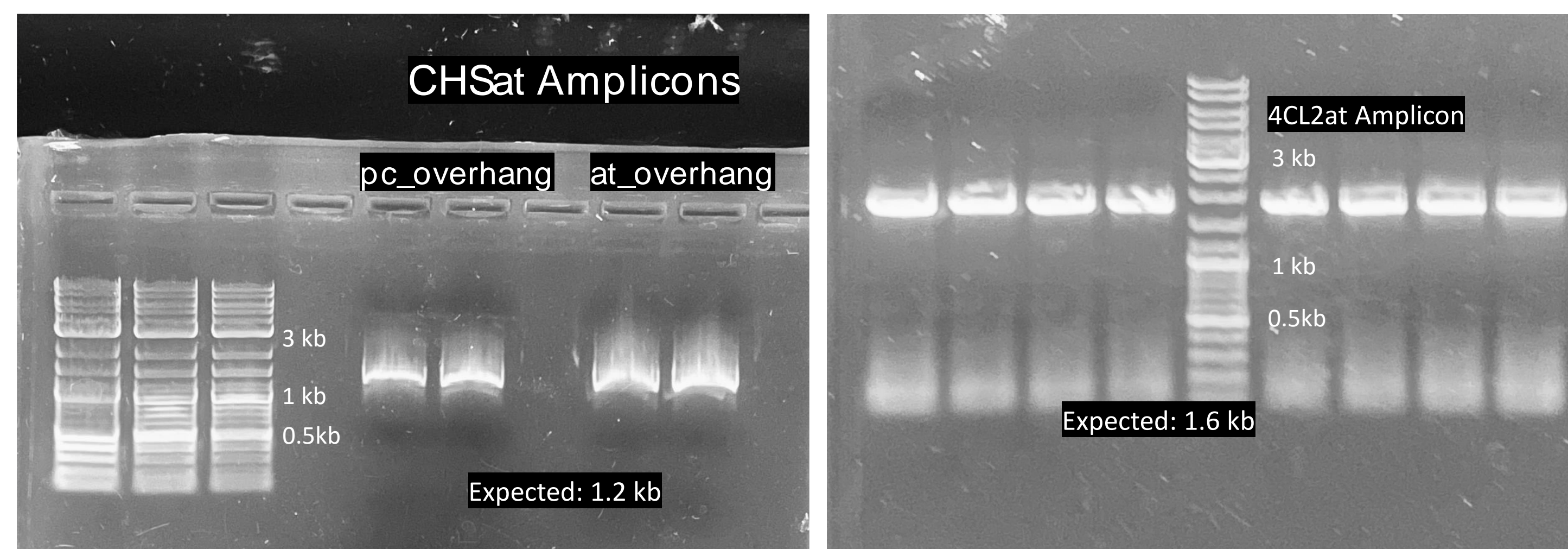
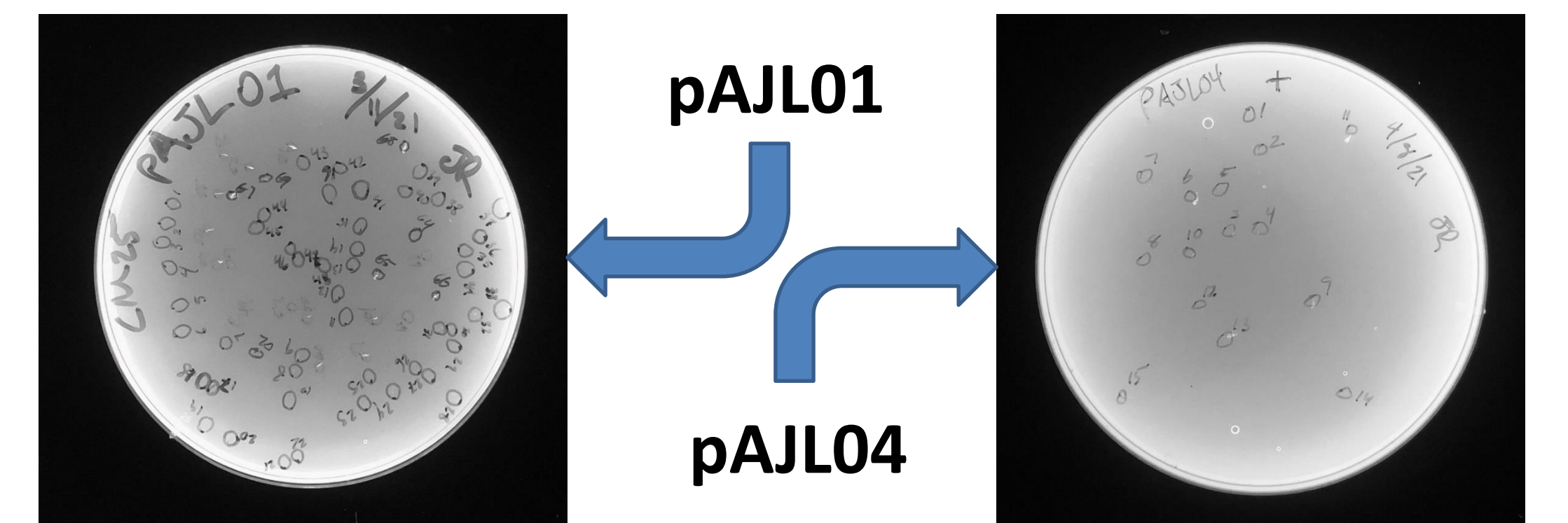
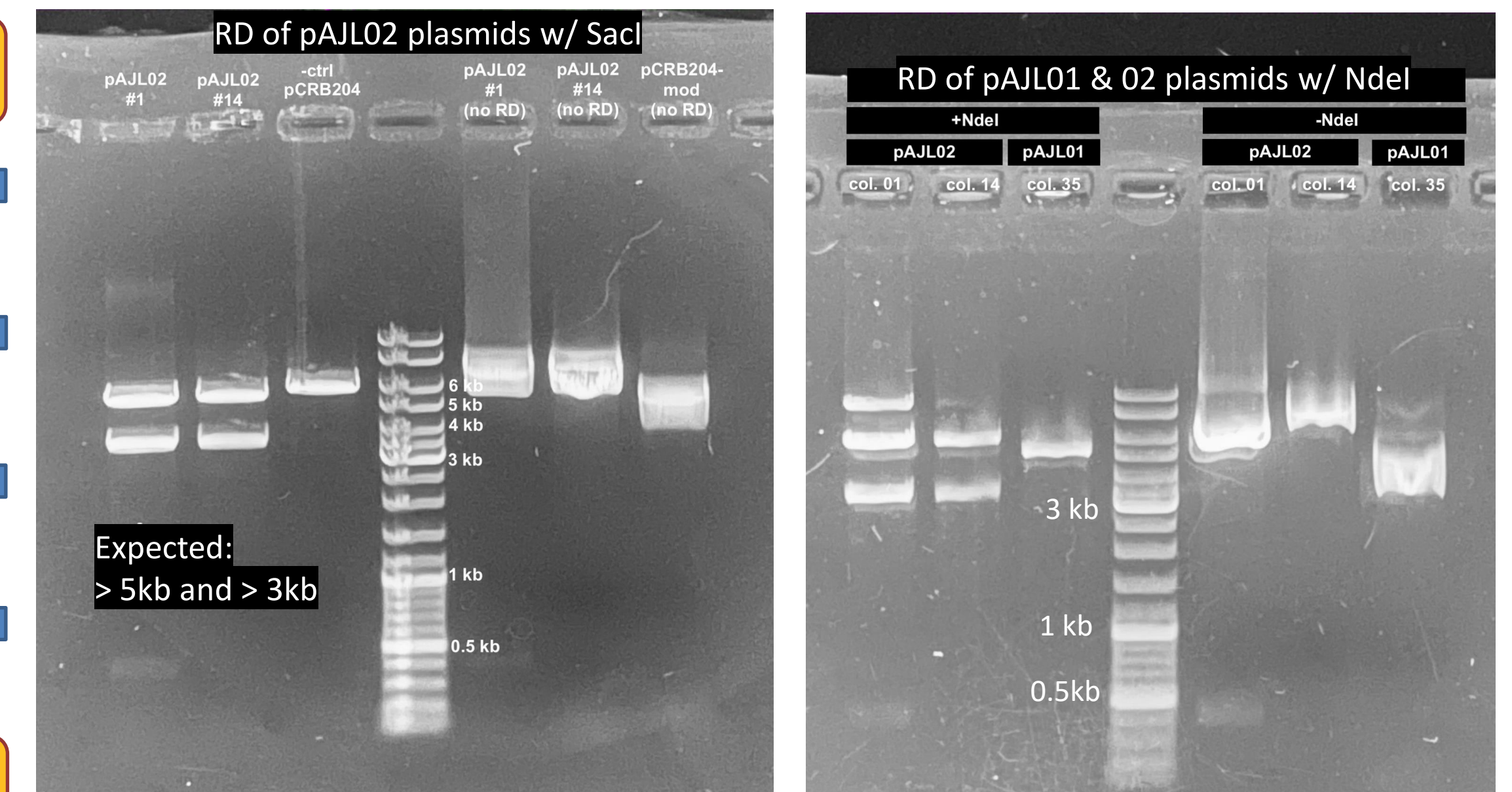

## Future Work

- Finish assembling, transforming, and sequencing all plasmids
- Determine baseline naringenin production
- Manipulate expression of ACC subunits and measure change in naringenin production

## Acknowledgements

Arren Liu- Graduate Mentor  
Arul Varman- Principal Investigator  
David Nielsen- Committee Member  
Varman Lab