

# RF (Radio Frequency) Micro-coil Design for Animal MRI

Zakarya Abdi, Biomedical Engineering  
Mentor: Sung-Min Sohn, Assistant Professor  
School of Biological and Health Systems Engineering

## Background

MRI is considered one of the most powerful imaging modalities to noninvasively acquire structural, functional, and biochemical information in humans, and further utilizing this capability for diagnostic purpose. An identify weakness of the NMR (nuclear magnetic resonance) “still suffers from the sensitivity weakness compared to all other approaches”, and the MR image quality suffers for this. There exist previous incarnation of the device for which I want to build upon and one such device is the 7T preclinical MRI system which was developed based on an optimized transmit/receive 2 in 1 birdcage coil which was built to conduct improved imaging in animals.

## Research Question

The inquiry be answered by this project would be whether the developed RF coil could generate the frequency of 297 MHz that is required to operate 7T MRI scanner by the Larmor frequency.

## Motivation

A custom-built RF coil is beneficial to improve MR image quality and some MRI studies that need special geometry and MRI-guided interventions such as deep brain stimulation.

## Research Method

The development of the RF coil frame, the resonating structure and the interfaced circuit will go through a series of research, simulation, fabrication, tuning, testing and modifying the design and repeating the process until we reach our determined goal. The first step is to numerical modeling and simulation to check the resonance frequency and generated magnetic field (B1) distribution inside the micro-coil. The second step is to fabricate resonating structure with a loop or spiral type to generate the frequency of 297 MHz that is required to operate 7T MRI scanner by the Larmor frequency. The third step is to design and fabricate tuning and matching circuit with variable capacitors to satisfy impedance matching (50 Ohm) at 297 MHz . The fourth step is to build the coil frame and housing using the 3D printer in the facilities at ASU. Then fifth step is to take all the material that has been built up to this point and bench test them with a network analyzer to check the frequency tuning and impedance matching conditions and generated magnetic field with a pickup probe. The sixth step is dependent on the fifth step and whether the necessary measurements is coming from the bench testing, if the values do not match the design will be re-evaluated and modified to improve the coil design. The last step is to prepare the MR scanner study if it is possible in the time period of this project.

## Obstacle Faced/Overcame

Initial problems that have arrived during the implantation of the 1-centimeter for the coil that invalidated the design of the loop. The second set of problem was the inability of the normal S-Param function to generate the flow of electricity of the circuit in advance design system. The current state of the system is being built through soldering of the components based on the data provided by the ADS.

## Finding And Progress Thus Far

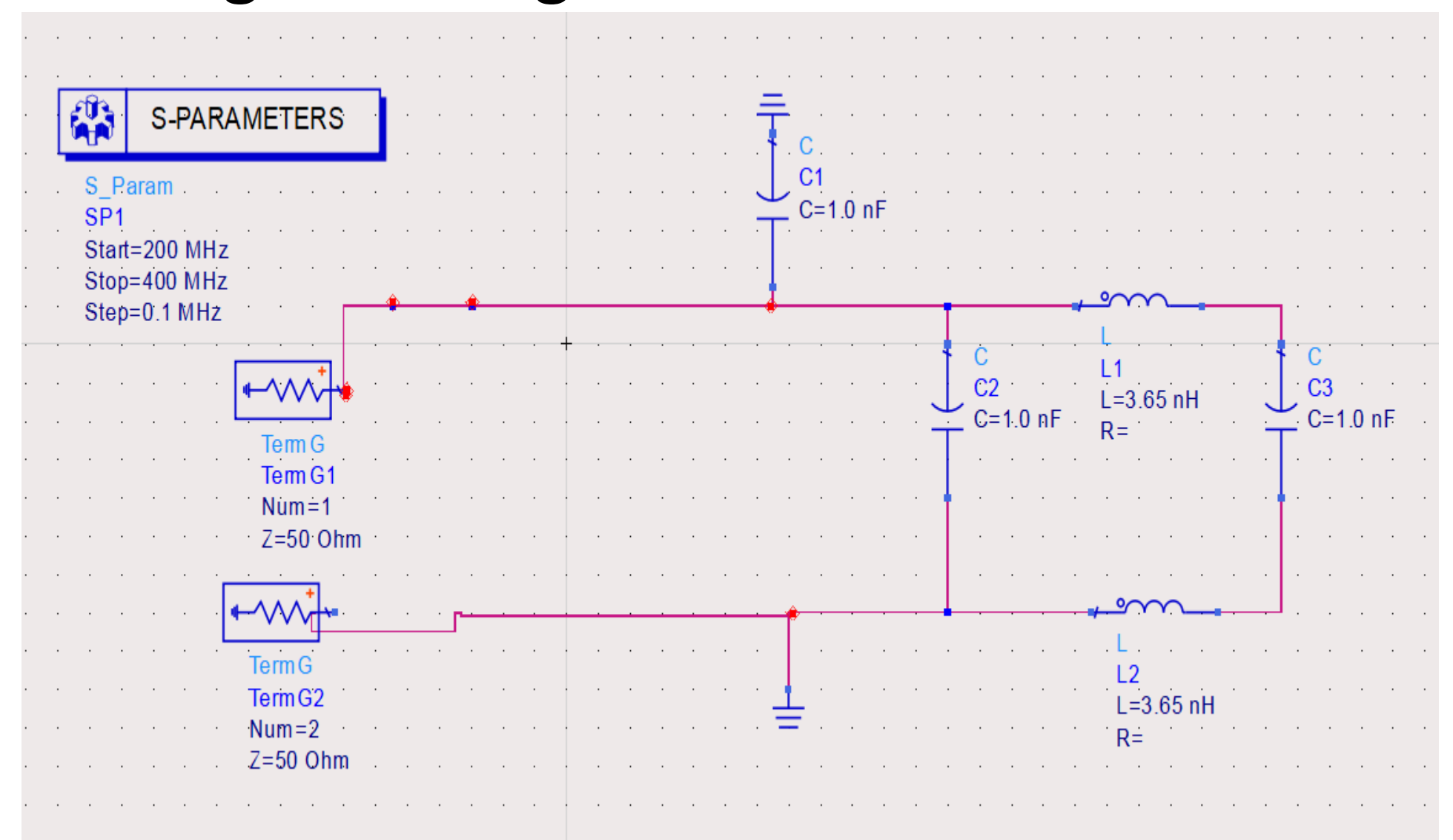

Figure 1: This represent the original design for the cooper loop based on the principal of a birdcage loop with a term components at the end of the cycle. This led to a problem of being unable to generate the necessary frequency for the 7T MRI Scanner.

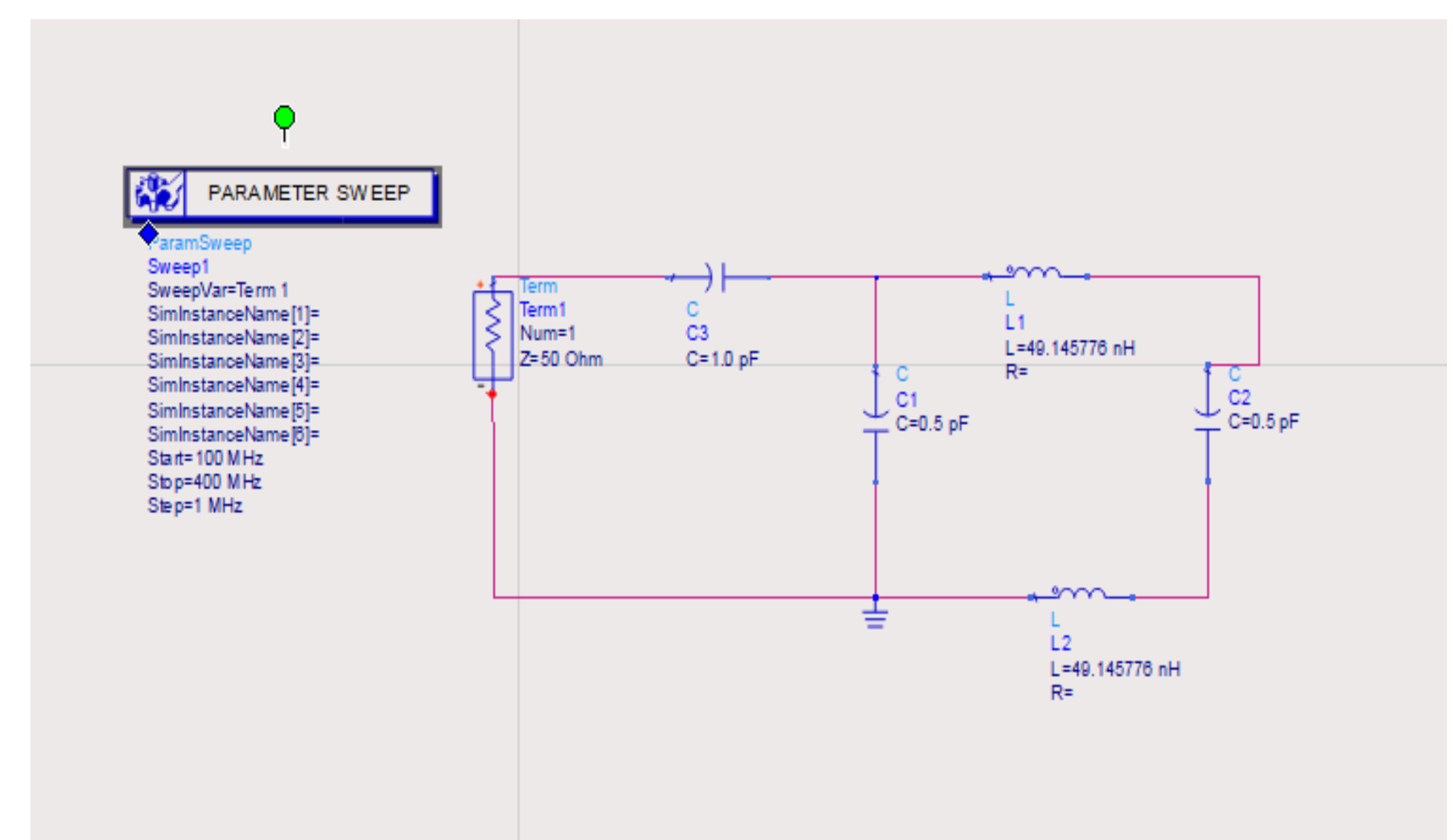

Figure 2: This represent the final design for the cooper loop based on the principal of a single loop with a term components that starts and ends the cycle. This led to the circuit to being able to generate the necessary frequency for the 7T MRI Scanner.

This project is based on two semester design, fabrication, testing, modification of the cooper loop to provided the correct frequency for the 7 Tesla MRI. I am in the middle of gaining the necessary skills to solder the components and to use a network analyzer to justify the results from the circuit design of advance design system and then make modifications.

## References

- [1]Weber, H., Baxan, N., Paul, D. et al. Microcoil-based MRI: feasibility study and cell culture applications using a conventional animal system. *Magn Reson Mater Phy* 24, 137–145 (2011). <https://doi.org/10.1007/s10334-011-0244-0>
- [2]Lopez Rios N, Pouliot P, Papoutsis K, Foias A, Stikov N, et al. (2018) Design and construction of an optimized transmit/receive hybrid birdcage resonator to improve full body images of medium-sized animals in 7T scanner. *PLOS ONE* 13(2): e0192035. <https://doi.org/10.1371/journal.pone.0192035>
- [3]Merrifield, Gavin & Mullin, James & Gallagher, Lindsay & Tucker, Carl & Jansen, Maurits & Denvir, Martin & Holmes, William. (2016). Rapid and Recoverable in vivo Magnetic Resonance Imaging of the Adult Zebrafish at 7T. *Magnetic Resonance Imaging*. 37. 10.1016/j.mri.2016.10.013.
- [4]Fakri-Bouchet L, Zahraoui M. Implantable microcoil for in-vivo magnetic resonance spectroscopy. *Int J Biosen Bioelectron*. 2017;3(2):237–240. DOI: 10.15406s/ijbsbe.2017.03.00056
- [5]Felder, J., Celik, A.A., Choi, C. et al. 9.4 T small animal MRI using clinical components for direct translational studies. *J Transl Med* 15, 264 (2017). <https://doi.org/10.1186/s12967-017-1373-7>